

nortech

FISO

⚡ ENERGY

The Nortech product line allows FISO to offer a complete line of products in order to meet customers needs in temperature monitoring for high voltage applications.

FISO's long experience in hot spot monitoring solutions provides a wide expertise in temperature sensing for high voltage environments. The product offering was renewed in order to provide solutions at a lower cost, but with the same reliability and quality.



FISO offers the most cost effective line of fiber optic temperature sensors for high voltage applications.



PRODUCTS AND ACCESSORIES

KEY ADVANTAGES

- DIRECT CONTACT •
- HIGH DIELECTRIC CONSTANT •
- NO CALIBRATION REQUIRED •
- NO CALIBRATION FACTORS •
- IMMUNE TO SIGNAL ATTENUATION •

APPLICATIONS

- POWER TRANSFORMER •
 - Core
 - Winding
 - Bushing
- LOAD TAP CHANGER •
 - Contacts
 - Oil
- GENERATORS •
- SWITCHGEARS •
- TRANSMISSION LINES •
- HIGH VOLTAGE CABLES •

SENTINEL

The Sentinel optical signal conditioner is a flexible, multi-channel fiber optic signal conditioner designed for direct, accurate and real-time temperature monitoring. Its new sensor health monitoring feature allows quick troubleshooting during system installation.

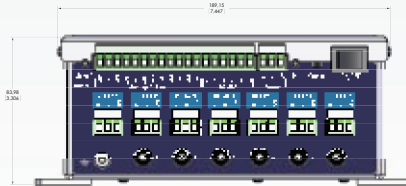

Nortech's complete line of products provides all the required items to instrument power transformers for hot spot monitoring. With **over 10,000 sensors** installed worldwide, our solutions have been tested and used with success.

TPT-62

STANDARD

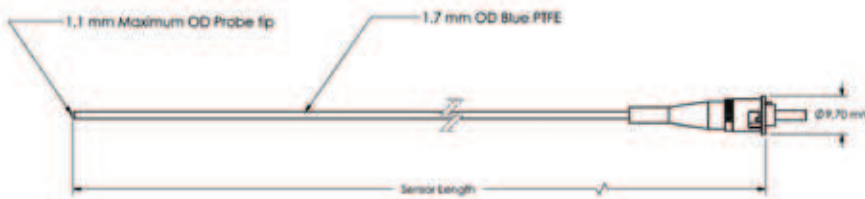

1.7 mm PTFE cable

HEAVY DUTY (for oil filled power transformers)

Improved Visibility High Strength Construction

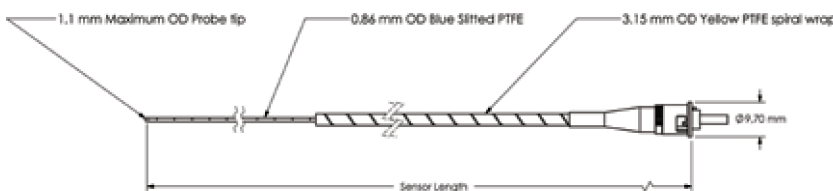

0.9mm PTFE cable and 3mm PTFE spiral wrap cable
Both cables are designed with transversal slits for a faultless oil flow into the sheath.

The TPT-62 sensor possesses a resilient construction and has dielectric resistant materials featuring complete immunity to EMI and RFI environments. **The heavy-duty version is specifically designed for permanent installation in oil-filled transformers.**

TPT-62 SENSOR	
Temperature range	-40°C to 225°C
Resolution	0.1°C
Accuracy	±1°C
Available length	1 to 15 meters (in .5m increment)
Sensor dimension	1.1mm
Certification	ASTM D-3426 ASTM D-149 IEC 243-1 IEC 243-3



	SENTINEL II	SENTINEL LITE
Datalogging	> 25 years	None
Relay	6 form C* with user-configurable set points 1 form C* for fail-safe system fault *10A 250VAC; 10A 30VDC	None
Power requirement	12-30 VDC, 13W	12-30 VDC, 9W
COMMON		
Number of channels	2, 4, 6, 8*, 10*, 12* (*with redundancy feature)	
Reading temperature range	-40°C to 225°C	
Resolution	0.1°C	
Accuracy	1°C	
Sampling rate	1 Hz	
Display	4x20 LCD	
Serial port	RS-232 and RS-485	
Communication protocol	MODBUS (ASCII, RTU), Nortech Proprietary protocol	
Analog output	4-20 mA configurable	
Light source	> 25 years	
Weight	1.5 Kg	
Dimension (HxWxD)	215 mm x 160 mm x 84 mm	
Operating temperature	-20°C to 60°C	
Storage temperature	-30°C to 85°C	
Relative humidity	95% RH non-condensing	
Environmental standards	IEC 60068-1 Environmental testing: general IEC 60068-2-1 Test A: cold IEC 60068-2-2 Test B: dry heat IEC 60068-2-14 Test N: change of temperature IEC 60068-2-30 Test Db and guidance: damp IEC 60068-2-78 Test Cab: damp heat, steady MIL-STD-810F Vibration and shock	
Immunity standards	IEEE C37.90.1-2002 EN 61326 EN 55011 Class A (Industrial) EN 61000-4-2 EN 61000-4-5 EN 61000-4-3 EN 61000-4-6 EN 61000-4-4 EN 61000-4-11	
Warranty	4 years	

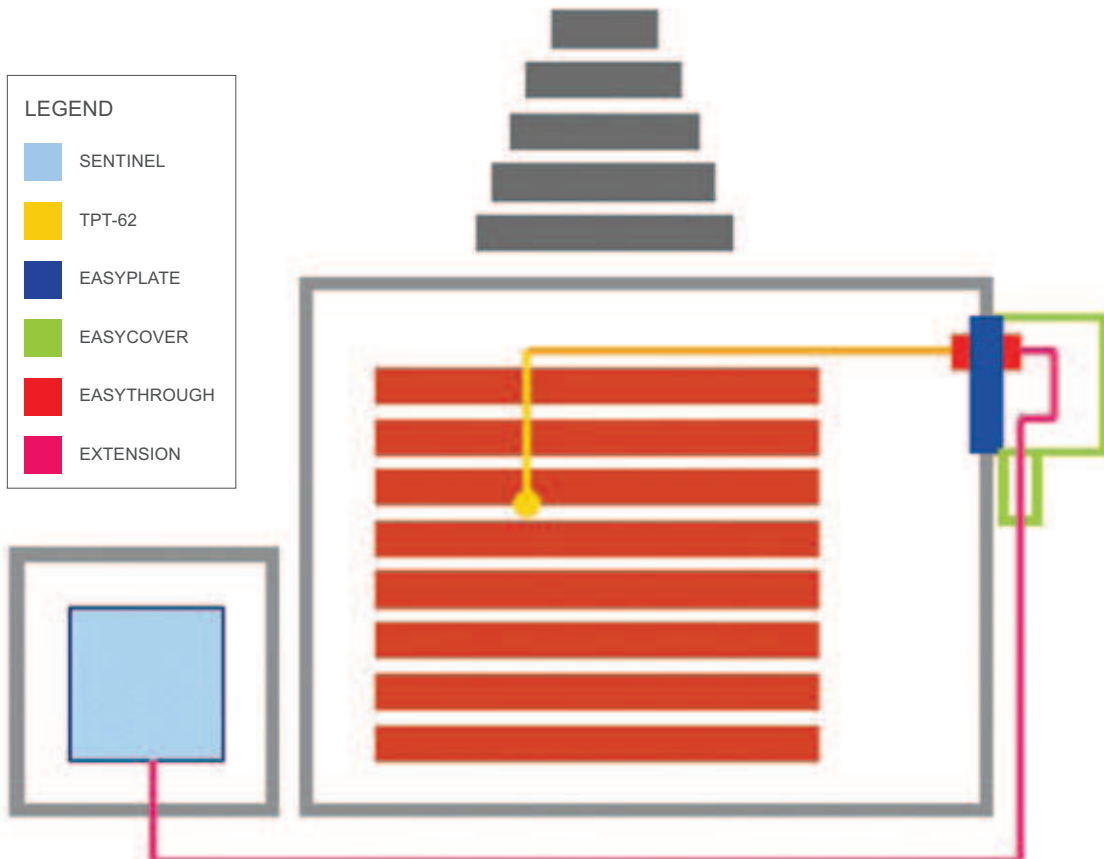
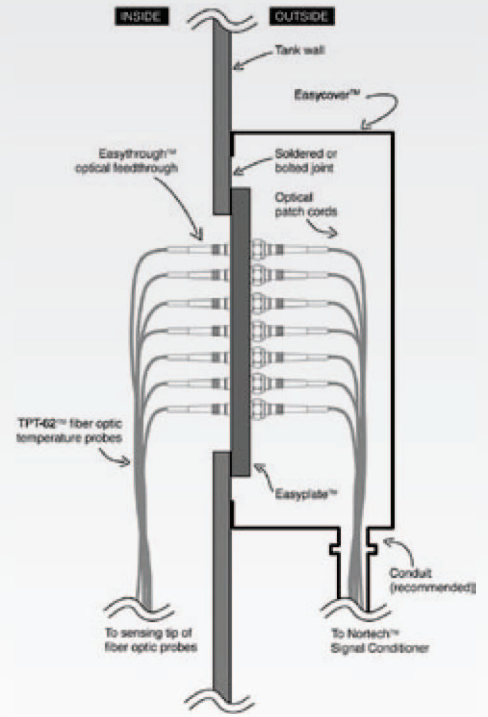

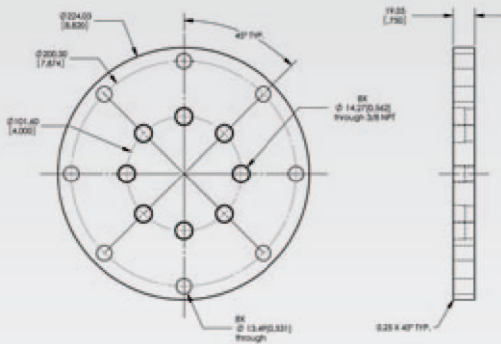

EASYPLATE

The Easyplate is a stainless steel or carbon steel customized circular plate that completes the integration of Nortech direct winding temperature measuring system.

Number of Easythrough mounting holes on the plate	1 to 12
NPT type	3/8" NPT pipe thread
NPT holes	1.43 cm (0.56")

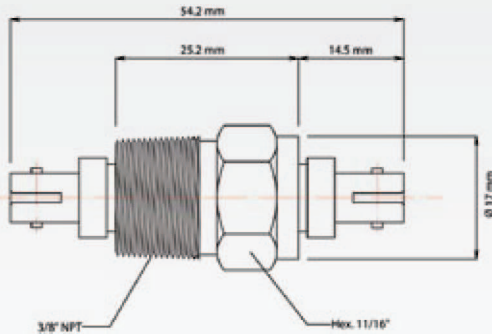

EASYTHROUGH

The Easythrough is designed to be installed on a tank wall or in any other sealed environment. Its simple and proven design will be mated with FISO's TPT-62 sensors.

Maximum long-term operating temperature	150°C
Maximum pressure	80 psi
Fitting type	3/8" NPT
Thread	ASPT; 60° thread angle, taper angle of 1°47', truncation crest are flat.
Material	Stainless Steel
Connectors	ST



EXTENSION

FISO's extension cords are specifically designed to be placed in harsh environments without compromising performance. Their Kevlar reinforcement provides a long-term mechanical durability.

Cable diameter	3mm OD
Cable length	Standard: 3, 5, 10 and 15 meters Custom: 1 to 100 meters
Cable jacketing	Polyurethane with Kevlar reinforcement
Connectors	ST
Temperature range	-55°C to 85°C
Others	Fungus Resistant UV Resistant Water Resistant High Flexibility



EASYCOVER

The Easycover is a protective cover dedicated in protecting the Easyplate. Its design allows an easy installation and an access to the fiber optic connections.

* For more details, feel free to contact us.

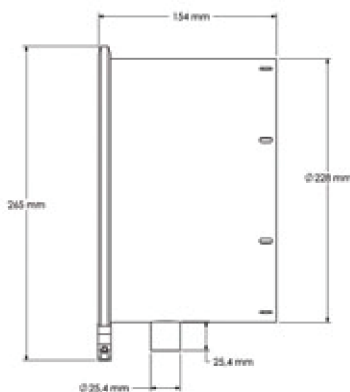



TECHNICAL NOTES

THE PRINCIPLE

FISO's fiber-optic temperature sensors for high voltage temperature measurement are based on white-light absorption/transmission by a GaAs (gallium arsenide) semiconductor. The effects of the temperature variations on this semiconductor are well-known and predictable. As the temperature of the semiconductor increases, the semiconductor's transmission spectrum (*i.e.* the light that is not absorbed) shifts to higher wavelengths. At any given temperature, transmission essentially jumps from 0% to 100% at a specific wavelength. This jump is called the absorption shift, and the relationship between the specific wavelength where the absorption shift takes place, and temperature, is predictable.

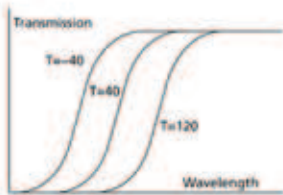

Why does this shift occur? The physical explanation for this phenomenon is found in the variation that occurs into the semiconductor's energy band gap. This "gap" refers to the energy required to bump the electrons in the material

into an excited state (as opposed to the relaxed, steady state). As more energy enters the semiconductor, in the form of heat as its temperature rises, the gap gets narrower—which means that less additional energy is required to excite an electron. The photons (particles of light) entering the semiconductor are what actually excite the electrons. If a photon is carrying enough energy to get an electron across the gap, it will be absorbed. If it does not carry enough energy, then it will be transmitted. The shorter a photon's wavelength is, the more energy it carries. Since the band gap narrows as the semiconductor's temperature increases, less energy will be required to jump across the gap, and photons with less and less energy (longer and longer wavelengths) will be absorbed "by the band", as they say. The effect is to move the absorption shift to longer wavelengths.

Consequently, measuring the position of the absorption shift gives a measure of the semiconductor's temperature. It is important to note that this technology is wavelength dependent instead of intensity dependent.

THE TEMPERATURE SENSOR

The TPT-62 sensor is based on the direct contact of temperature measurement. Traditional temperature sensors like thermocouples and RTDs (resistance temperature devices) work on the same principle. In other words, the semiconducting material must be touching the object or be immersed in the liquid or gas to be measured. The more intimate the contact and the smaller the thermal mass of the sensing tip, the faster the semiconductor will respond to changes in temperature. We then want to be able to deliver light to the semiconductor and measure what is absorbed. That is the function of the optical fiber.

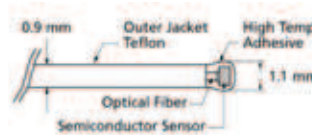

A tiny semiconductor of GaAs semiconductor is bonded to one end of a well polished optical fiber. On one side of this semiconductor, a reflective dielectric film has been installed. Dielectric means it does not conduct electricity. All the materials share this property ("high dielectric strength"), which is one of the principal advantages of our sensor technology over traditional temperature sensors like thermocouples and RTDs (which use wires to convey an electrical signal).

The length of the optical fiber is covered with a PTFE (Teflon®) sheath, making it very resistant to aggressive chemical environments as well, as an additional perforated PTFE sheath (spiral wrap) for added ruggedness and even oil circulation. The entire end assembly (semiconductor and end of the fiber) is then embedded in high temperature adhesive to protect the sensor (the semiconductor) from chemical and mechanical aggressions. Consequently, the only barrier to direct contact is this adhesive.

The position of the absorption shift is determined by using a proprietary signal analysis algorithm and is then correlated to temperature. The computation of the absorption shift does not depend on signal intensity for this particular instrument, but only the wavelengths of the light are of interest. Consequently, the various factors that contribute to the attenuation of the optical fiber (fiber length, number and quality of connections, fiber diameter and composition, bending) do not impose any serious constraints to our system. Furthermore, since the semiconductor's response to temperature is universal, all of our sensors are interchangeable with no need for calibration or entry of factors when swapping sensors. FISO's approach gives reliable, repeatable temperature measurements without the errors that may result from a loss of power in the connectors or a bending of the optical fiber.



FISO Technologies Inc. is a leading developer and manufacturer of fiber-optic sensors and signal conditioners. Committed to providing customers with innovative and reliable solutions for measuring parameters such as temperature, pressure, displacement and position, strain and load as well as refractive index in harsh environments and challenging applications, FISO's targeted markets are medical, process control, energy and research laboratories.

Founded in 1994, the company is part of the Roctest Group (RTT), a publicly traded company in Canada. Its products are sold in more than 75 countries through a network of representatives and distributors. Since 2003, FISO Technologies meets the requirements of the ISO 9001 and ISO 13485 certifications. The company is assessed and certified by BSI Group strictly applies its quality policy day after day.



FISO Technologies Inc.

500 St-Jean-Baptiste Ave., suite 195
Quebec (Quebec) Canada G2E 5R9

Phone 418 688-8065
Fax 418 688-8067
Email info@fiso.com
Web www.fiso.com

FISO Technologies Inc. reserves the right to make any changes in the specifications of their products without prior notice.
© 2010 FISO Technologies Inc.
Printed in Canada

MC-00233 R2

